

# NimbleGen Microarray Dryer

*Effective washing and complete removal of wash solution prior to scanning is critically important when processing DNA microarrays. Salt crystallization and other residue formations resulting from insufficient washing or removal of wash solution can compromise vital data, contribute to high background signal, or both. Additionally, protection of the hybridized array from environmental degradation during the wet-to-dry transition is essential to maintain fluorescent signal.*

The NimbleGen Microarray Dryer helps to ensure production of high-quality images with minimal residue without the use of noxious chemicals, such as acetonitrile. The array drying step is performed in a protected environment to reduce atmospheric and light-induced degradation of Cy dyes. A key component of the NimbleGen microarray workflow, the NimbleGen Microarray Dryer is used with NimbleGen Hybridization Systems, Mixers, and Wash Buffer Kits to provide the complete array processing solution for NimbleGen DNA Microarrays.

## Advantages

- **Better Sensitivity:** Minimizes background noise and helps prevent dye degradation without the use of organic dye savers
- **Better Reproducibility:** Safely removes background wash residue which compromises assay reproducibility
- **Environmentally Friendly and Safe:** Prevents wet-mode ozone degradation of cyanine dyes without the use of organic solvents like acetonitrile
- **Fast and Easy-to-use:** Holds 2 NimbleGen Array Processing Racks for simple batch processing of 1 to 24 slides

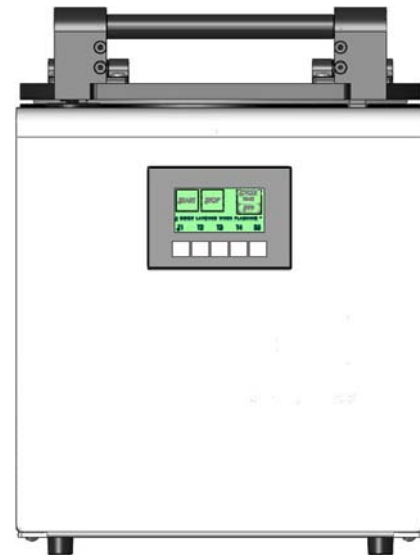

▲ **Figure 1:** NimbleGen Microarray Dryer, front.

▼ **Figure 2:** NimbleGen Microarray Dryer, top.

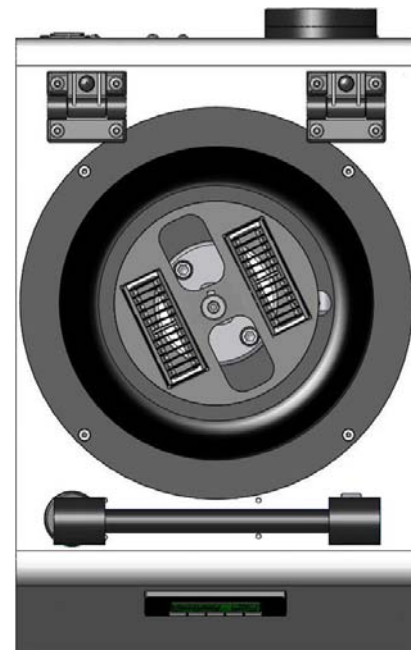

**Table 1. Array Dryer Ordering Information and Specifications**

<b>Catalog numbers</b>	05223636001 - NimbleGen Microarray Dryer, 100-120V, 50/60Hz 05223644001 - NimbleGen Microarray Dryer, 220V, 50Hz
<b>Dimensions (W x D x H)</b>	26.5 x 19.75 x 24 inches (673 x 501 x 610mm)
<b>Weight</b>	77lb (35kg)
<b>Capacity</b>	Up to 24 slides
<b>Slide formats</b>	Standard 1 x 3 inches (25.4 x 76.2mm) glass
<b>Electrical requirements</b>	100-120V or 220V
<b>Time to maximum speed</b>	<2 seconds
<b>Maximum speed</b>	1,800rpm
<b>Drying time</b>	2 minutes
<b>Environmental conditions</b>	Designed for indoor use only Relative humidity: <40% - non condensing
<b>Permissible ambient temperature</b>	15 - 25°C
<b>Compliance standards</b>	UL/EN 61010-1, EN 61010-2-20, IEC 61326-1 <b>CE</b> The NimbleGen Microarray Dryer complies with the requirements of the following European Directives: <ul style="list-style-type: none"> <li>■ 89/336/EEC (Electromagnetic Compatibility Directive)</li> <li>■ 73/23/EEC (Low Voltage Equipment Directive)</li> </ul>

**HIGH-DEFINITION PRODUCTS**

**CGH (Comparative Genomic Hybridization)**

Measure DNA copy number differences between a test and reference genome.

**ChIP-chip**

**(Chromatin Immunoprecipitation on chip)**

Measure transcription regulation, the histone code, polymerase activity, or any DNA-protein binding.

**DNA Methylation**

Correlate promoter and genic DNA methylation with gene expression and compare differential methylation between cells, tissues, and other research samples, such as tumor samples.

**Gene Expression**

Analyze transcription occurring in any sequenced genome.

**Sequence Capture**

Enrich large regions or thousands of loci from complex genomic DNA in preparation for high-throughput sequencing.

**Custom Arrays**

Accelerate your development of new and cutting-edge scientific applications.

**Instruments**

Increase throughput while achieving high quality, reproducible results.

**Kits**

Simplify the experimental process with prepackaged reagents and validated protocols.

**Software**

Facilitate the research pipeline from array design to image extraction to data analysis with our suite of software.

**Training**

Receive detailed instruction in both the theory and practice of genomic and epigenomic research techniques at our customer workshops, at our facility or yours.

**MULTIPLE OPTIONS FOR ACCESS**

**NimbleGen Arrays**

Includes arrays designed and manufactured by NimbleGen for research facilities worldwide.

**NimbleGen Full Service**

Includes array design and manufacture, sample labeling, hybridization, scanning, data extraction, and preliminary data analysis.

**Contact: Roche NimbleGen, Inc.**

Toll-free in US: (877) NimbleGen / (877) 646-2534  
(608) 218-7600

[www.nimblegen.com/arrayssupport](http://www.nimblegen.com/arrayssupport)



HIGH - DEFINITION GENOMICS

© 2008 Roche NimbleGen, Inc. All Rights Reserved.

05397723001 • 1/09

For life science research only.  
NIMBLEGEN is a trademark of Roche.



Roche NimbleGen, Inc.  
504 S. Rosa Road  
Madison, WI 53719 USA